

**MODEL F-1** Axial component Trimmer/Former. High speed output of 26 components per turn. Easy to use set-up gauge.

**MODEL R-1** Radial component Trimmer. Easily adjustable cut lengths in less than one minute.

Both models are upgradable with motor drive & counter (DAC), reel holder (RH-1) and loose feed (LF-4) for axial components.

Any APS handcrank component former can be mounted on the same motorized drive and counter.

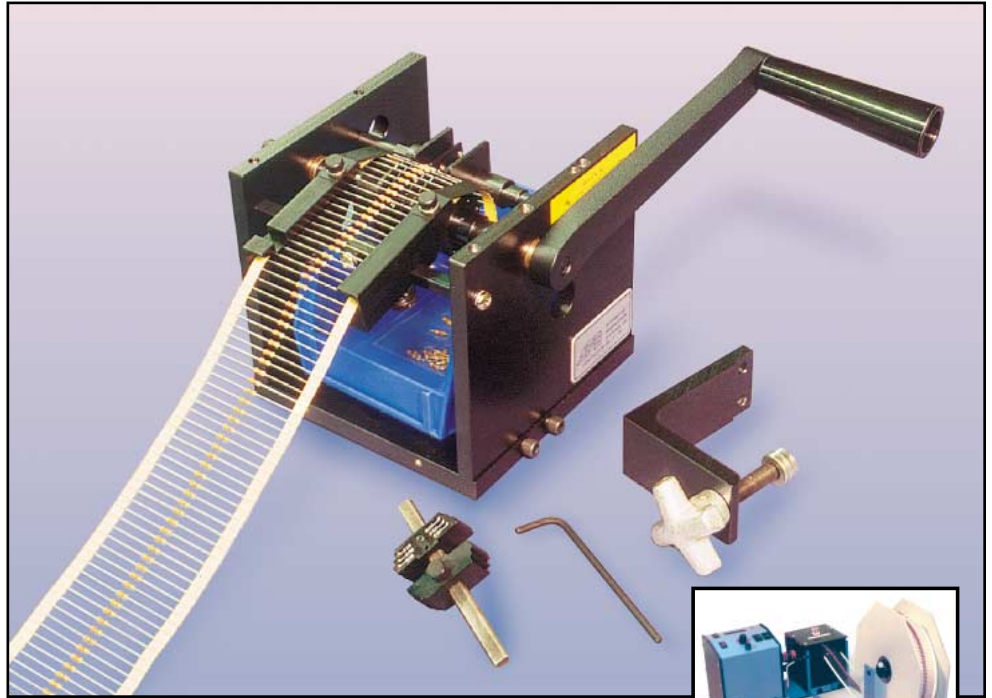

F-1 handcrank axial trimmer/former

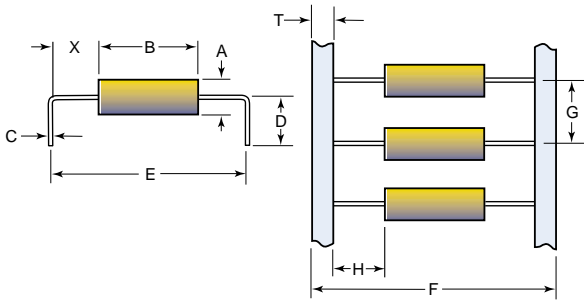

**F-1 Specs:**

	A Body Dia	B Body Length	C Lead Dia	D Lead Length	E - Lead Center to Center	F Component Width	G Tape Spacing	H- Tape Component Distance	T Tape Width	X- Bend to Body Distance
MIN (in)	0.01	0.00	0.01	0.12	0.20	0.75	0.20	0.15	-	0.035
MIN (mm)	0.25	0.00	0.25	3.05	5.08	19.05	5.08	3.81	-	0.90
MAX (in)	1.00	1.88	0.05*	0.63	2.06	4.63	1.00	2.00	0.375	-
MAX (mm)	25.40	47.75	1.25	16.00	52.33	117.60	25.40	50.80	9.53	-

\*With .030 to .050 (0.08 mm to 1.27 mm) tooling

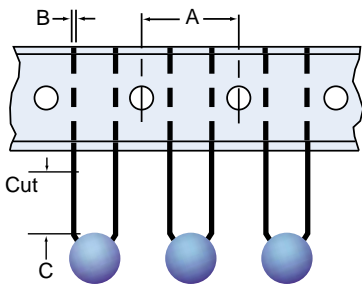

**R-1 Specs:**

	A Tape Hole Spacing	B Lead Dia.	C Lead Cut Length
MIN (in)	0.500	0.01	0.05
MIN (mm)	12.7	0.25	1.27
MAX (in)	0.500	0.050	0.500
MAX (mm)	12.7	1.25	12.7

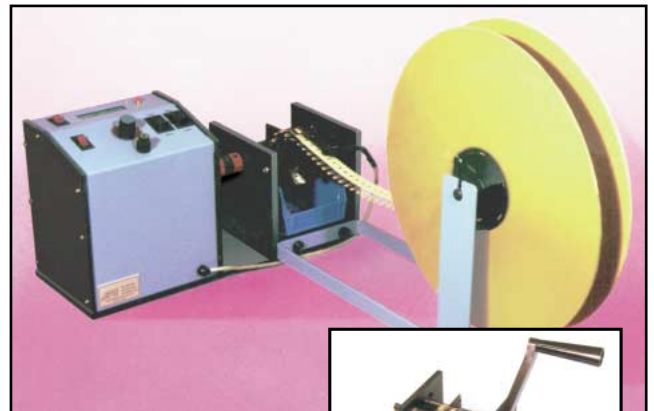

AR-1 radial lead trimmer with motor drive & counter and reel stand



R-1 radial lead trimmer

